

Coda Audio Rigging System's Maintenance

The following general maintenance procedures apply to Coda Audio CiRAY and SC2-F/ SCV-F, rigging parts and accessories.

As there are some differences to certification and other local regulation requirements from one territory to another. The following maintenance procedures are supplied as a guide to general good maintenance of your rigging system. This guide should be studied in conjunction with any local rules and regulations for your territory. This guide does not replace any local rules and regulations and should not be taken as an overriding guide to any local rules and regulations that you may need to adhere to in your own territory.

General

All rigging parts, including cabinet fixtures and fitting, fly-bars, extension bars, shackles and dollies should be fully inspected every 12 months. The owner of the equipment should set up their own schedule for undertaking this work. It is recommended that the first general inspection should be undertaken 12 months from date of first system use.

In addition to an annual inspection of all parts; Coda Audio recommends that a general visual inspection of all parts should take place before each system is installed or used. A further visual inspection should be undertaken at the end of each use. These inspections should be performed by a suitably experienced and qualified system technician, and a log should be kept of all inspections completed.

It is important to remember that the cabinet fixtures and fastenings form an integral part of the overall suspension (flying) system. Therefore, great care must be taken when using, transporting or storing your cabinets and accessories so as to avoid any physical damage, either via hard contact with floors, walls or other equipment coming into contact with your speaker cabinets and their accessories. Coda Audio provides a variation of transport dollies, flight cases and soft covers to help protect your system, and these should be used at all times. Coda Audio does not accept any liability or responsibilities for damage, how so ever caused, to your systems or accessories at any time. Coda Audio recommends the use of the accessories made available, at all times without exception. It is the responsibility of the equipment "owner" to keep all equipment in good working order and for it to be used only as intended, within its listed specification area of use. Should you have any questions relating to the correct usage of the equipment, please contact your Coda Audio representative or Coda Audio direct for further assistance and support. Contact information is listed at the back of this document.

This document will only discuss and cover Coda Audio supplied products and accessories. This document does not take into account any equipment which is used in conjunction with Coda Audio products and accessories, such as chain motors, electric hoists, steel wire, shackles or other rigging equipment.

Overview

The correct usage of your Coda Audio system must be adhered to at all times. If you are unsure of any point, it is always best to ask before you start using the system; this will not only assist in a better understanding of your equipment, but also further your general knowledge of Coda Audio systems.

This document is not a training manual. For any and all training related information, you must contact your local Coda Audio supplier or Coda Audio Hannover Germany for further information.

It is Coda Audio's requirement that all systems will only be used by suitably experienced and qualified individuals. This includes both the use of the system and its general maintenance. Any and all test certificates that may be required for your territory must be obtained in accordance with local rules and regulations; this is the responsibility of the equipment owner, not Coda Audio or its local sales representatives.

Cabinets

All Coda Audio line array cabinets are designed to be used in both ground stack and suspended formats (using the appropriate accessories designed for these functions).

Your Coda Audio speaker cabinet (where applicable) has integrated steel flying hardware which has been designed and fitted to the cabinet by Coda Audio during the manufacturing process. All such flying hardware has been designed to perform its function in line with the overall system design and specifications for use.

Example of integrated flying hardware:



Image 1: CiRAY 3D view



Image 2: CiRAY Rear view



Images 3: SC2-F and SCV-F

The pictures above show examples of the integrated flyware on cabinets designed to be suspended either from a supporting Fly-Bar, Fly-Frame or from one another below the Fly-Frame. The external and internal flyware parts have been designed from high grade steel, which has been anti-rust coated and then painted with multiple coats of paint to its finished level.

Normal wear and tear on all parts which form part of the connection process will result in some paint being scratched and in time even worn off. This is normal and to be expected. It will not affect the function of the parts or their construction.

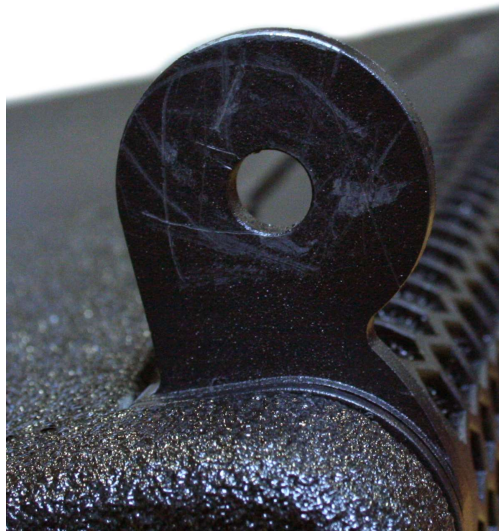

Image 4: Example picture of CiRAY (used) inter-cabinet connection arm

This picture shows an example of an CiRAY inter-cabinet connection arm after multiple usage; slight surface to surface rubbing takes place as the arm is positioned into its “female” corresponding position. Where the two surfaces meet, paint may be rubbed off. This is normal. There is no need to repaint this urgently – this can remain as it is or be re-painted at an annual inspection and service time.

Checks should be made to all metal to metal connecting surfaces, to ensure that no actual hard scoring of the metal has taken place. Hard scoring only takes place when two metal surfaces are rubbed together with excessive pressure on one or both surfaces. If evidence of this is found on any two-mating metal surfaces a full test and inspection is recommended.

Checks should be made to all metal work for any damage that may arise from cabinets or other equipment bumping or banging into one another during transport, usage or storage.

Checks should be made for any larger signs of damage, such as may be caused by long periods of transport where cabinets are not flight cased or dollied, or where other equipment may come into contact with the cabinets. A simple visual check made by lightly running your hand along the metal work, looking for scratches, pitting or other dents in the metalwork will show up any problems easily.

Checks should also be made at the same time to all fixings and fastenings used to fix the metal work to the cabinet.

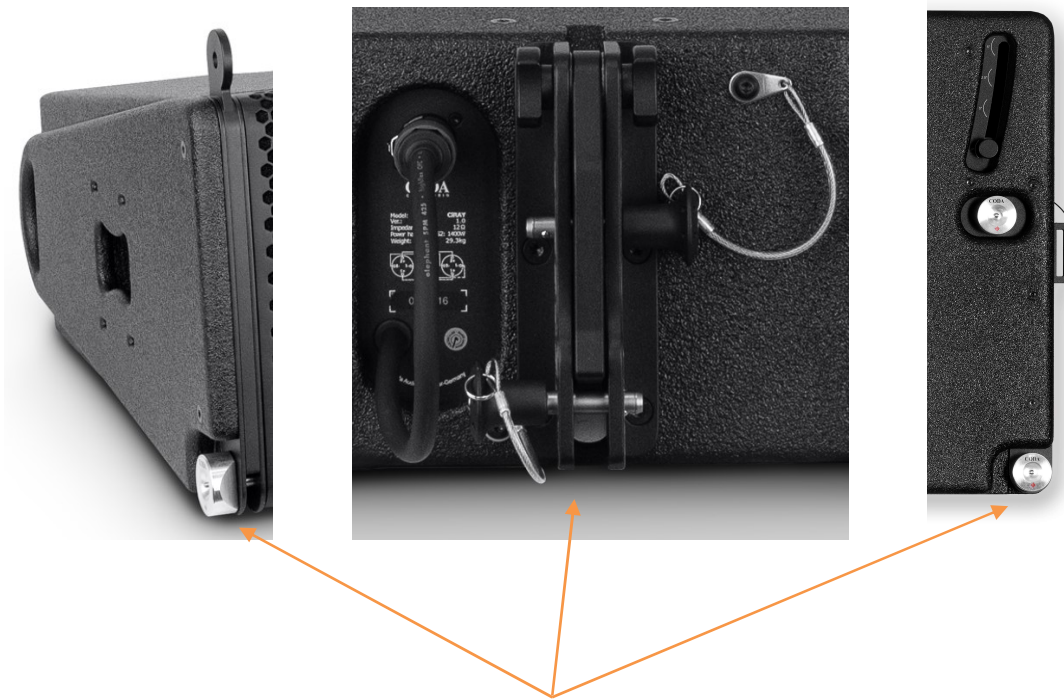

Fixings / fastenings

Images 5, 6 and 7: Typical examples of fixings / fastenings used on Coda Audio cabinet

These fixings and fastenings should show no signs of movement, or be loose in any way; they should be flush fitting to the metalwork surface. These fixings and fastenings are installed at the Coda Audio factory and under normal conditions will not move. However, under some long-term transport conditions, particularly where roads are bad, long term vibration might have an effect. Undertake a visual inspection at regular intervals. Once every 12 months undertake a full manual check, as follows;

Check each screw fixing in turn using the appropriate tools (Coda Audio use a variation of fixings / fastenings; Torx head – Allen key type) make sure you use the correct tool format and size. Simply insert the tool into the fixing head, and apply a little pressure in the clockwise direction. Normally there will be no movement and this indicates that the fixing is tight and all is OK.



Torx



Allen

Image 8: Two types of fixing head used

Do not apply greater pressure than 1 kg of test pressure. Do not attempt to force the fixing in any way. Do not use air tools.

If any fixing or fastening is found to be loose, carefully tighten until the stop position is found. Do not over tighten as this may lead to damage of the fixing threads.

If movement is found on any fixing, perform a full check to all metalwork and fixings on the cabinet, as movement in one area normally indicates that the cabinet has been stressed in some way and a full check is required. Perform a visual inspection first, followed by a fixings inspection using the correct tool.

Flying Pins

A specially designed Coda Audio retaining pin is always attached to its metalwork on the cabinet and operates on a "Spring & Ball" system that does not come away from the cabinet. This design has achieved a near zero loss of pins since its introduction. The pin works simply by depressing the plunger and moving the complete mechanism forwards to lock and backwards to unlock. Like all Spring & Ball systems once the pin is in place and the plunger released, the pin will be locked in place. To remove the pin, depress the plunger and pull the complete mechanism backwards, fully.

Regular visual inspections of the pins should be undertaken. Once every 12 months a full physical inspection should take place, at this time inspect the pin for alignment and any operational defects that do not allow free movement and operation.

It is vital that all pins are correctly secured during operational use, transport and storage. Pins left un-secured will become a hazard to staff, and may also be damaged which must be avoided.



Image 9: CiRAY side view



Image 10: SC2-F/ SCV-F side view

Part number: Coda-Pin F ViRAY

These pins form a vital part of the flying system and its safe operation; they should be visually checked at regular intervals for any damage or poor functionality.

Check the pin plunger is depressing correctly – check that when depressed the two ball locks at the end of the pin, move into the body of the pin, and back out again when the pin plunger is released.

Check that without the pin plunger depressed, the two ball locks are fixed in the “out” position and will not go back into the body of the pin

Every 12 months run a full check on all pins for correct operation.



Image 11: CiRAY and SC2-F/ SCV-F pin in transport position

Always train staff to place the pins in this position when not in use, this will help protect the pin from damage and will also keep the pin with the cabinet at all times. Pins which are not in transport position may get knocked off or damaged in transit. This can cause delay at setup time.

The pins supplied by Coda Audio are the correct specification for their designed usage, if you lose a pin, please contact your Coda Audio representative for replacements; do not replace with none Coda Audio parts.

Check regularly that the pins are in place, replace with original Coda Audio parts as required. The CiRAY system also uses a separate retaining pin for the rear part of the flying system.



Image 12: CiRAY Rear hardware pin

Part number: Coda-Pin-R ViRAY

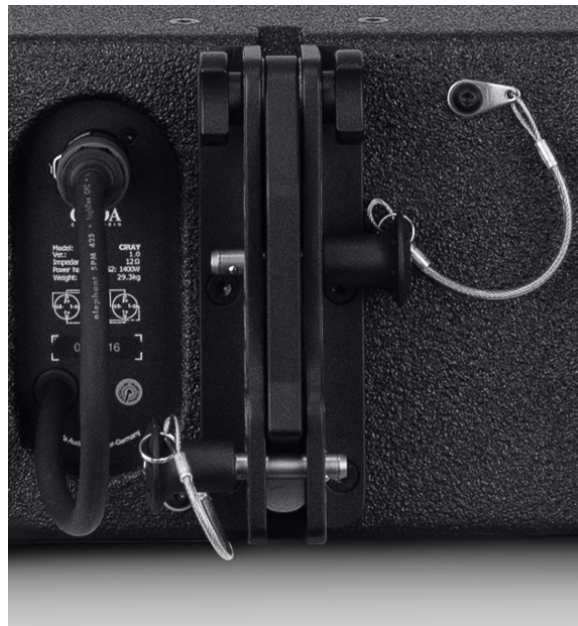

Image 13: Coda-Pin-R ViRAY in single cabinet transport position

This pin is housed and used in various parts of the flying system and is also retained to the flying system by a steel retaining wire.

The pin has a location home point when not in use as shown in the image above.

Always make sure that all staff are trained to place these pins in the correct position when not in use. The steel retaining wire is just to hold the pin in close proximity to its area of use.

Due to the nature of usage, it is possible for the steel retaining wire to become broken if caught or snagged on something while the cabinet is being moved, the steel retaining wire is made so that if it does become stuck or snagged in something it will break after a certain amount of pressure, this is by design, as this retaining wire is only used for keeping the pin with the cabinet. This retaining wire has no load bearing function; it must not be used for any other purpose than retaining the pin to the cabinet.

Check regularly that the retaining wire and pin are in place, replace with original Coda Audio parts only as required.

Never use damaged pins for operational use; this is unsafe and may lead to accident or injury.

Do's & Don'ts

Do

- Always run a visual inspection of the cabinet(s) before and after use.
- Always run a full inspection of the cabinet(s) once every 12 months, check all rigging metalwork and fixings for wear & tear, check for rust, check for alignment.
- Always check that no metal parts have become damaged in any way, this includes bends (alignment to another part), corrosion via rust or other type.
- Check all "pins" are working and fully functioning regularly.
- Check all product labels, indicators and data labels are in position and not damaged, replace any which are worn or missing.
- Do obtain spare parts only from your Coda Audio representative.
- Do flight case any accessories in suitable designed flight cases.
- Do use Coda Audio transport dollies / flight cases and soft covers.

Don't

- Don't forget to visually inspect your system before use.
- Don't forget to visually inspect your system after use.
- Don't forget to check all pins are in place and functioning correctly.
- Don't use none Coda Audio replacement parts or accessories.
- Don't over tighten "fixings / fastenings" when checking.
- Don't allow lose items to be carried via any transport method, always pack correctly.
- Don't allow un-skilled operation of any part of the system.
- Don't over-load any part of the system.
- Don't forget- "Safety First" whenever using the system.

Annual Inspection

The annual inspection of your cabinet(s) should be formed of three parts

- Visual inspection of metalwork and woodwork
- Physical inspection of all metalwork and woodwork
- Acoustical check of all components and electronics

We will only deal with points 1 & 2 in this document.

Point 1: run a visual inspection of all cabinets; clearly mark any cabinets that require attention based on the visual inspection.

Point 2: run a physical inspection of all cabinets; this should include checking all metalwork, fixings, fastenings and the cabinet woodwork.

Under normal conditions your cabinet(s) should require nothing more than a clean after all testing has been completed.



Woodwork: The CiRAY and SC2-F/ SCV-F wooden enclosures are covered with polyurea coating. This material is especially designed to prevent any damage to the cabinet. Any kind of scratches on the material can be touched up with HAMMERITE DIRECT TO RUST METAL PAINT SMOOTH AEROSOL SDSHM106 BLACK (applied locally with a cotton pad). The cabinets cannot be repainted by an end user. Polyurea painting requires specialist painting equipment and techniques. Cabinets should be returned to Coda Audio GmbH if a complete polyurea repaint is required.

Metalwork: The metalwork can be “touched-up” where scratches have occurred to maintain good overall condition. As the metalwork is powder coated, please do not use any wood paint on these parts. For small scratches, please use a paint marker or permanent marker. For larger areas which require repaint, please use a black spray colour, colour code RAL9005. In difficult climatic conditions of excessive heat, cold or humidity, a very light rub-over with a light oil cloth on all metalwork can be advantageous, as this may help to reduce the effects of oxidisation to the metal parts. Please be aware that any slight coating of oil might make handling more difficult and will lead to slight oil deposits coming off on hands. We recommend that if you are using an oil cloth rub-down on the metal parts, that you inform all staff and users, so that they are aware and may take the opportunity to wear protective clothing and take additional care when handling the cabinets and fly-bars.

Never allow any residual levels of paint, oil or cleaning fluids to build up on the surfaces of the cabinet or its metalwork and accessories.

CiRAY and SC2-F/ SCV-F have transport “soft covers”. We recommend the use of these covers at all times during transport and storage, they will help protect from knocks and bangs and provide a good level of protection from dust, dirt and poor weather conditions.

Please note that in wet conditions cabinets and metalwork should not be allowed to stand in soft covers for prolonged periods of time without being allowed to dry off naturally. If cabinets become wet during use, they should be allowed to dry off as soon as possible. Allowing any wood or metal product to stay wet for periods longer than 24 hours without suitable ventilation will lead to oxidisation and potential mould taking hold. Always dry your product off naturally, without forced heat, as soon as possible; this should also apply to flight cases.

Once dry, undertake a visual inspection of each system part and if required rub a lightly oiled cloth over all metalwork.

Fly-bar and extension bars and accessories

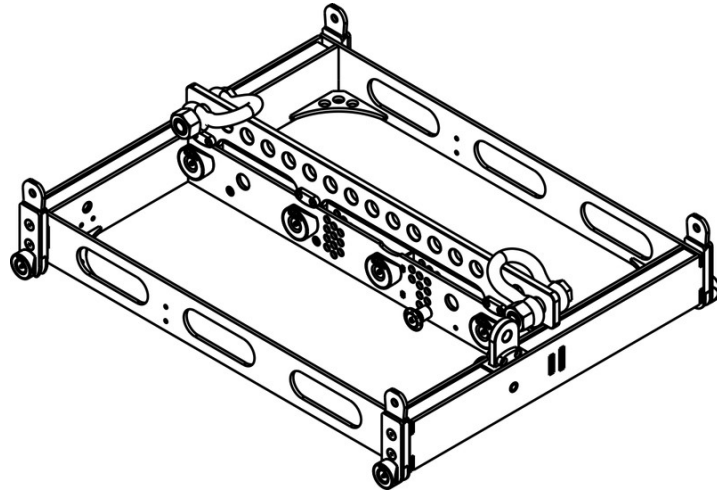

Image 14: FR-AR-Set/ Frame for flying or ground stacking AiRAY/ ViRAY/ CiRAY or SC2-F/ SCV-F
in various combinations

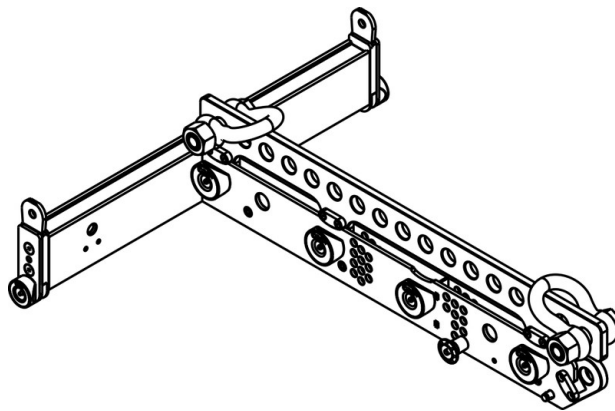

Image 15: FRT-AR Set/ Frame for flying AiRAY/ ViRAY/ CiRAY

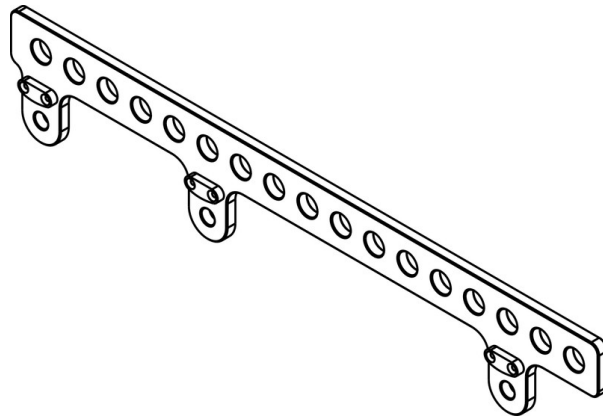

Image 16: EXBAR AR/ Extension bar for FR-AR and FRT-AR

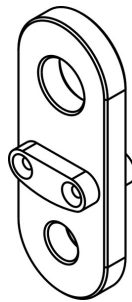

Image 17: ADS/ Single Pickpoint Adapter

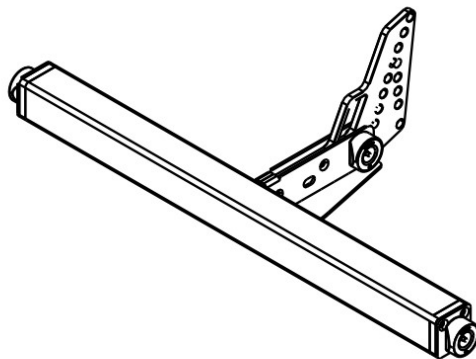

Image 18: CGA/ CIRAY Ground Stack Adapter. Max 8x CIRAY cabinets can be stacked on SC2-F/ SCV-F.

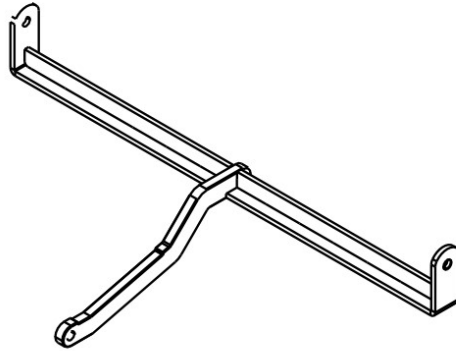

Image 19: CR-LINK / Adapter allows Top (max 6x) - Sub combination without additional frame.

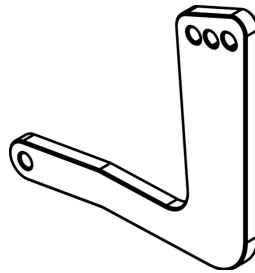

Image 20: VR-AR-LINK/ Enables rear connection of ViRAY (max 8x) below CiRAY.



Image 21: SA-AR/ Splay adapter for CiRAY

Images 14 to 21 show all Fly-bars, extension bars and adaptors with part code for the CiRAY system.

The various fly-bars are shown in the above pictures. Their individual usage is not part of this document. We will only discuss basic maintenance of these items here.

The Fly bars FR-AR, FRT-AR, EXBAR-AR, ADS have a WLL (Working Load Limit) of 800kg each.

- WLL for CGA -240kg (8x CiRAY)
- WLL for CR-LINK -180kg (6x CiRAY)
- WLL for VR-AR-LINK -200kg (8x ViRAY)
- WLL for SA-AR -800kg

ATTENTION:

Use should only be undertaken by suitably experienced and trained personnel.
Coda Audio GmbH assumes no responsibility for the use, misuse or misapplication for this product.

- Do not exceed the Working Load Limit
- Do not allow shock or impact loads
- Do not use if the product components are visibly distorted or worn

Check the loading capacity calculator before use!

You will find this general information and warnings on the following components on all CiRAY accessories:

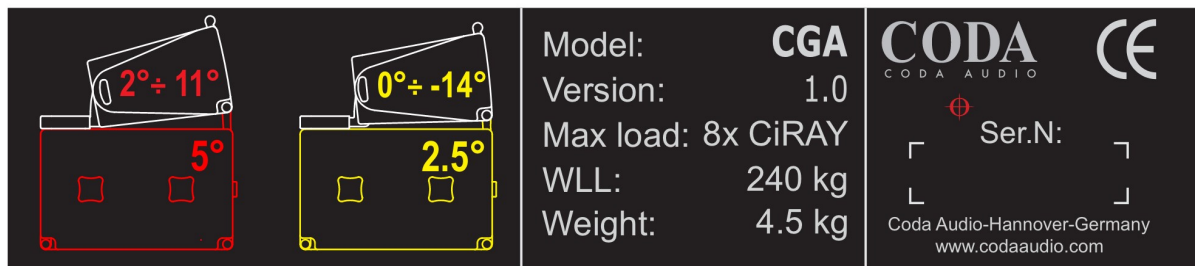

Image 22: General information and warnings on CGA

For CiRAY systems, there is an option to transport 6 x CiRAY cabinets on specifically designed transportation and rigging Dollies protected with a transportation cover; this is the recommended way of transporting the system. The most important point here is that all rigging equipment must be cared for and transported correctly; failure to do so may lead to accident or injury. It will definitely lead to a reduced life span of the rigging system.

A visual inspection of all rigging hardware should be undertaken at regular intervals; and a full inspection and test certification (as required) should be undertaken once every 12 months.

This inspection should be as already described, with the following additions.

Where fly-bars have been supplied by Coda Audio with “shackles” these may require local territory certification, please check with your local authorities.

Where extension bars single pick point adapters in combination with the FR-AR and FRT-AR are used make sure all pins are locked and are in place – do not use when pins do not lock correctly!



Image 23: Large CODA-Pin EX-AR used on the FR-AR/ FRT-AR for EXBAR-AR and ADS

Where any safety pin is used; always make sure these are used and in place with the system, failure to use these may lead to accident or injury.

Check these washers and safety pins are always in place and used each and every time the system is used.

If any of these parts become damaged or are lost, you must only use Coda Audio replacement parts as each item has a specification designed for its use, none replacement or replacement from another source will compromise safety and could cause damage or injury. It is vital that all parts of the flying system are only used up to the maximum load weight permitted by design. Never overload any part of the system beyond the published specifications. These specifications can be found for each system on the Coda Audio website at www.codaaudio.com.

If you are unclear about the specifications of your system, please ask your local Coda Audio representatives for assistance.

All flying accessories, for example, extension bars, must be transported in suitable flight cases.

While these parts are made from high grade steel and are normally designed using a 10:1 factor for safety reasons, care must be taken when in use, transport or storage, so that the parts do not become damaged at any time. These parts have specifically designed connection and operation points which are critically positioned and must stay so for correct operation to take place. Avoid dropping any part onto any hard surface. Avoid miss-use or any use other than their specific function. NEVER use tools such as hammers on any part of the system. If there is a need to use a force greater than that of the human hand for any reason, only use specialist tools with none metal heads.

If any part of the system is subject to miss-use or overloading or any form of stress tension, the parts concerned and all those that might have been connected should be fully inspected and if required, be load tested by a fully certified testing centre.

The design of all flying hardware parts has a high degree of accuracy making alignment of one part to another very easy while minimising excessive tolerance. The connection point from the fly-bar to the cabinet is such a critical point.

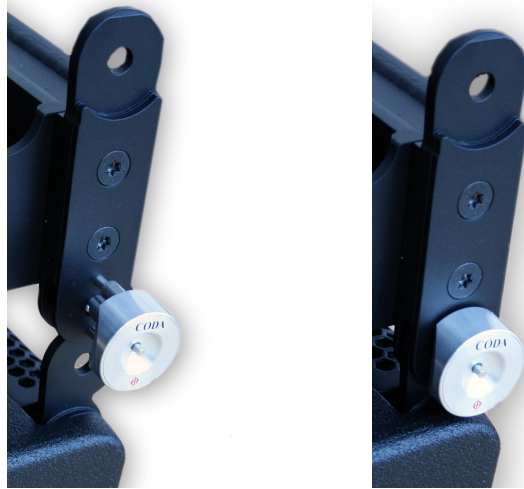

Images 24 and 25: Fly-bar to cabinet connection point for CiRAY

This point is on the underside of the fly-bar, therefore when preparing a system for use, it is natural to place the fly-bar on the ground; when the bar is placed on the ground it will rest on the connection points. Make sure that the bar is not dropped or in any way placed heavily on any hard surface, as this might lead to some deformity of the connection point which will result in miss-alignment.

When checking your cabinets and flying system, always remember to remove any sticky tape, (Gaffe or insulation tape) which may have been applied. The removal of residual tape or glue will not only keep your system looking its best; it will also help stop the build up of dust and dirt which will form on any sticky surfaces. A clean and tidy system is normally respected far more than one which is seen as dirty!

Coda Audio supplies all welded rigging accessories with their specific Magnetic Particle Examination Report.



Report № 100-174/19.06.2015 MAGNETIC PARTICLE EXAMINATION

1. Client	Coda Audio GmbH Hannover Germany, Boulevard der EU 6		Order No	678
2. PROJECT				
Project		Object	Item tested	Drawing №
FR AR		Serial No52532	fillet welds	750.1.28/01.103(1)
% welds tested	Surface condition	Diameter [mm]	Thickness [mm]	
100	as welded, flush	n/a		
Material	Heat Treatment	Type of welding	Type of welds	
Carbon steel	-	141	fillet	
Quality Level : EN ISO 5817 – Level C				
Acceptance Criteria : EN ISO 23278 – Level 2				
3. Procedure : EN ISO 17638, GQP 10.1.3				
Magnetization Type	<input type="checkbox"/> Current magnetization	<input checked="" type="checkbox"/> Yoke	<input type="checkbox"/> Coil	<input type="checkbox"/> Permanent magnet
Equipment OMD Blacklight 230/12, ser.№11-114 (brand / model/ser №)	Current <input checked="" type="checkbox"/> AC <input type="checkbox"/> DC	Demagnetization <input type="checkbox"/> Yes <input checked="" type="checkbox"/> No		
Contrast paint (brand / type)				
Magnetic particles CRACK Marker /MR 76 F (brand / type)	<input type="checkbox"/> Black/wet	<input checked="" type="checkbox"/> Fluorescent	<input type="checkbox"/> Dry	
Surface <input type="checkbox"/> Ground <input checked="" type="checkbox"/> Polished <input checked="" type="checkbox"/> As welded	Lighting		<input type="checkbox"/> Natural	<input checked="" type="checkbox"/> UV
4. Technique				
Two continuous magnetization at 90deg. to each other were carried out according to EN ISO 17638, fg.4				
5. Examination results				
100% MT was carried out on all fillet welds on Serial No52532 No rejectable indications were noted. The quality of the inspected frame is in conformity with the requirement of EN ISO 5817-level C.				

NDT Technician	
Name: dipl.eng. Asen Asenov, EN 473 MT level 2	Place of examination: Sofia
Signature: 	Date of examination: 19.06.2015

Image 26: Copy of an FR-AR Magnetic Particle Examination Report

Terminology:

Fly-Bar

The metal frame used to suspend the speaker cabinets, also referred to as a Fly-Frame

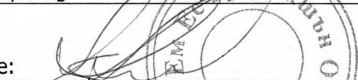
Metalwork

All metal parts fixed to the cabinet that are used as part of the suspension system

Fixings and Fastenings

All screws, bolts, washers, safety pins, shackles as used to fix one part to another

Pins – (Pin & Ball)

Connecting pin used to fix one cabinet to another or a cabinet to a fly-bar or dolly

Contact Information :

Coda Audio GmbH
Boulevard der EU6
30539 Hannover
Germany

Tel: +49 (0) 511 866 558 88
Fax: +49 (0) 511 866 558 87
Email: contact@codaaudio.com
Web: www.codaaudio.com